



Design of a Dual-polarized Square Waveguide Antenna Fed by a Microstrip Patch

Songyuan Xu^{*1}, Galsan-Yondon Ariunbold^{*2}, Shu Li^{*3}, and Bierng-Chearl Ahn^{**}

This work was supported by the National Research Foundation of Korea(NRF) grant funded by the Korea government(MSIT) (No.2018R1D1A3B07049588)

Abstract

This paper presents a new dual-polarized square waveguide antenna fed by a microstrip patch. The proposed antenna consists of a square waveguide, a square microstrip patch, two orthogonal coplanar waveguides feeding the patch by proximity coupling, and an air-filled cavity backing the patch. Wideband characteristics have been obtained by feeding the patch on the reverse side of the patch and by backing the patch with a thin rectangular cavity. An optimum design has been obtained from parametric analysis. The designed antenna operates at 35-37 GHz with reflection coefficient of less than -10 dB, port-to-port isolation of greater than 24 dB, gain of greater than 9.5 dBi, and boresight cross-polarization discrimination of greater than 28 dB.

요약

본 논문에서는 마이크로스트립 패치에 의해 급전되는 새로운 이중편파 정사각형 도파관 안테나를 제안하였다. 제안한 안테나는 정사각형 도파관, 정사각형 마이크로스트립 패치, 패치를 근접결합으로 급전하는 2개의 직교하는 코플래너 도파관 및 패치를 받치는 공기로 채워진 공동으로 구성된다. 패치를 뒷면에서 급전하고 패치를 얇은 사각형 공동으로 받침으로써 광대역 특성을 얻었다. 패러미터 분석 결과로부터 최적 설계를 얻었다. 설계한 안테나는 35-37GHz에서 -10dB 이하의 반사계수, 24dB 이상의 포트 간 분리도, 9.5dBi 이상의 이득 및 28dB 이상의 빔축 방향 교차편파 분리도를 가지고 동작한다.

Keywords

dual-polarized antenna, waveguide radiator, wideband, microstrip patch

1. Introduction

Dual-polarized antenna elements are widely used in such applications as polarization diversity [1] and radar target discrimination [2][3]. Dual-polarized square waveguide antennas are useful as a reflector feed and

an array element [4]. Narrow-band excitation of a square waveguide can be done using dual coaxial probes [5] or a gap-fed patch [6], while wide-band operation requires quadruple ridges [7] and an orthomode transducer (OMT) [8]. In [6] a dual-polarized feeding method has been proposed employing

* Dept. of Radio Communications Eng., Chungbuk National University · Received: Oct. 31, 2019, Revised: Dec. 12, 2019, Accepted: Dec. 15, 2019

- ORCID¹: <http://orcid.org/0000-0001-8551-6863>

- ORCID²: <http://orcid.org/0000-0001-6888-420X>

- ORCID³: <http://orcid.org/0000-0003-2674-9004>

** Professor, Radio and Communications Eng., Chungbuk National University

- ORCID: <http://orcid.org/0000-0001-7977-8760>

· Corresponding Author: Bierng-Chearl Ahn

Dept. of Radio and Communication Eng., Chungbuk National University, Cheongdae-ro 1, Cheong-ju city, Chungbuk, Korea

Tel.: +82-43-261-3194, Email: bician@cbu.ac.kr

a microstrip patch for a square horn. The coaxial probe feeding is simplest of all but its port isolation is poor. The gap-fed patch offers a good port isolation over a very narrow bandwidth [6]. Use of quadruple ridges or an OMT leads to wide bandwidth as well as high port isolation. Their principal disadvantages are structural complexity and large size.

In this paper, a new wideband square waveguide antenna fed by a microstrip patch is presented. Wideband dual-polarized characteristics have been obtained by feeding a cavity-backed square microstrip patch with two orthogonal coplanar-waveguide transmission lines through proximity coupling. The patch then excites the orthogonal TE_{01} and TE_{10} modes in the square waveguide. In the following, detailed design of the proposed antenna is presented. The CST Studio Suite 2019 has been employed in the antenna design.

II. Antenna Design

Fig. 1 shows the structure of the proposed antenna where constituents are disassembled to help the reader's understanding.

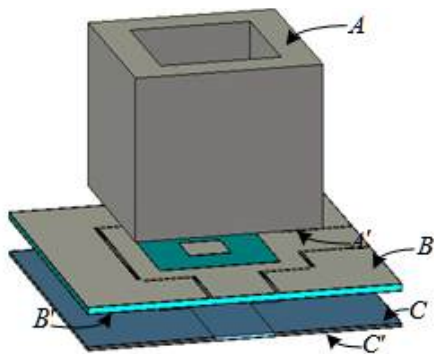

Fig. 1. Structure of the proposed antenna

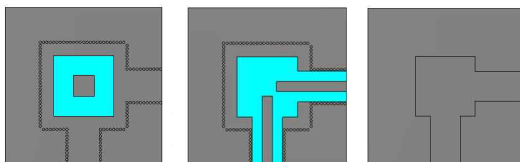

Fig. 2. Plane views of faces B, B' and C of Fig. 1

The proposed antenna consists of a square waveguide (A), a printed circuit board (B, B') containing a square microstrip patch on the front side and two orthogonal coplanar-waveguide transmission lines on the back side, and a metal plate (C, C') containing the air-filled cavity. Fig. 2 shows plane views of faces of the printed circuit board (B, B') and the metal plate (C).

Table 1. Antenna design requirements

Parameters	Specifications
Frequency	35–37 GHz
Gain	> 8 dB
Reflection coefficient	< -10 dB
Port-to-port isolation	> 20 dB
Polarization discrimination	> 20 dB @ boresight

Table 1 shows the design requirements of the antenna. The required bandwidth is not obtainable with a direct-fed microstrip patch. The bandwidth is greatly increased by proximity feeding the microstrip patch and by backing the patch and by backing the patch with a cavity.

The first step in the design of the proposed antenna is the determination of the square waveguide cross section. A large cross section results in the excitation of higher-order modes while a small one leads to a narrow bandwidth. A good choice of the square waveguide's width and height for the desired frequency 35–37 GHz is 7.20 mm. With this choice, the cutoff of the TE_{10} (TE_{01}) mode occurs at 20.83 GHz, while the TE_{20} (TE_{02}) is cut off at 41.66 GHz. The TE_{11} mode with its cutoff frequency of 29.46 GHz is strongly suppressed due to the even symmetry in the waveguide excitation.

The next step in the design is the choice of the substrate. The Rogers RD/duroid 5870 substrate with $\epsilon_r = 2.33$, $\tan \delta = 0.002$, $h = 0.45$ mm, $t = 0.035$ mm has been selected. Next a printed circuit transmission line feeding the patch is selected. Among many forms of planar transmission lines, a coplanar

waveguide with a via-hole fence has been selected for its advantages such as suppression of the surface-wave coupling (thus high port-to-port isolation) and easy mounting of circuit elements of the RF front-end module. Fig. 3 shows the cross section of the printed circuit board containing a microstrip patch on the top face and the CPW feed lines on the bottom face.

The final step in the antenna design is the determination of the size of the cavity backing the square patch. The function of the cavity is the widening of the bandwidth and the suppression of the backward radiation from the patch. The cavity width and height determine the cutoff frequencies of the TE₁₀ (TE₀₁) and TE₂₀ (TE₀₂) of the cavity. Good performance is obtained when the cavity width and height are same as those of the square waveguide inner wall. The depth of the cavity is kept as small as possible for the required antenna bandwidth. A larger depth results in higher-order mode excitation leading to poor performance in port-to-port isolation and polarization discrimination.

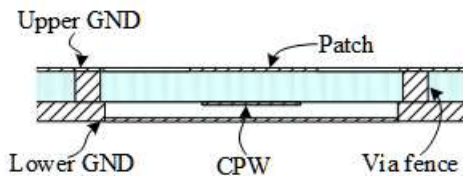

Fig. 3. Cross section of the printed circuit board

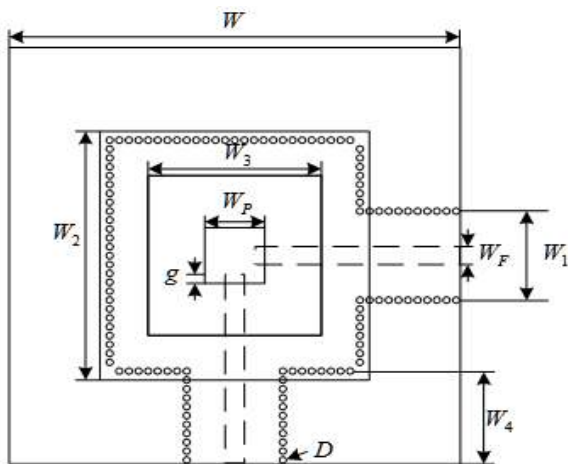

Fig. 4. Dimensional parameters of the proposed antenna

Fig. 4 shows the important dimensions of the proposed antenna and Table 2 shows their values. The waveguide inner and outer wall dimensions are same as W_3 and W_2 respectively while its height is 8.0 mm. The cavity depth is 0.20 mm, which is same as the depth of the recessed region in the face C of Fig. 1

Table 2. Dimensions in mm of the designed antenna

Parameter	Value	Parameter	Value
W	18.75	W_F	1.20
W_1	4.00	W_P	2.50
W_2	11.20	D	0.30
W_3	7.20	g	0.45
W_4	4.18		

The final design of the antenna is obtained by a combination of theory, parameter sweep and optimization. The most critical dimensions in the antenna design are the feed gap g and the waveguide wall width W_3 .

Fig. 5 shows the input reflection coefficient versus the variations in the feed gap. The feed gap g is fine tuned to obtain a reflection coefficient of less than -10 dB at 35-37 GHz. The feed gap has minor effects on the port-to-port coupling. With all other dimensions fixed, the waveguide wall width W_3 has sensitive effects on the reflection and port-to-port coupling as shown in Fig. 6.

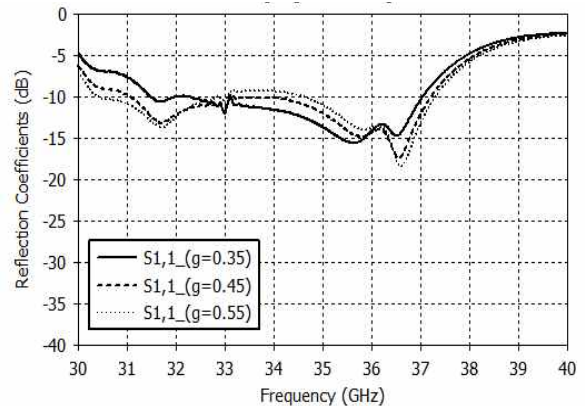
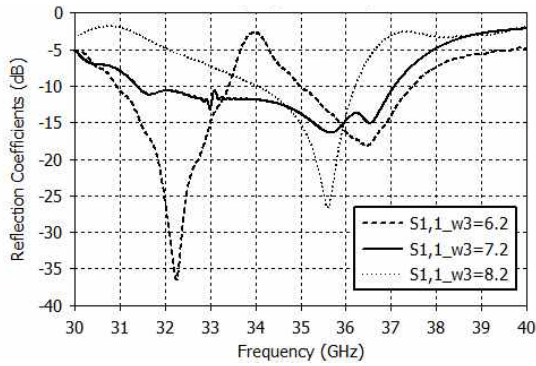
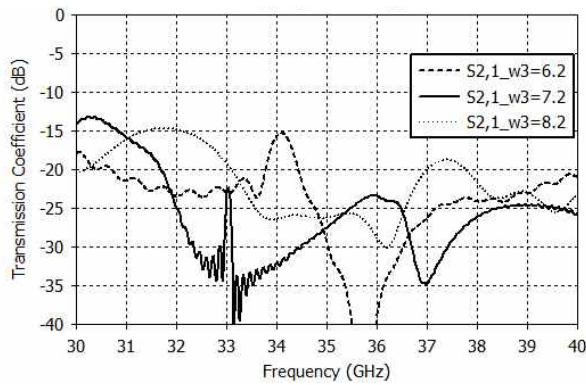

Fig. 5. Reflection coefficient versus feed gap



(a)



(b)

Fig. 6. Effects of the waveguide width on (a) the reflection and (b) the port-to-port coupling

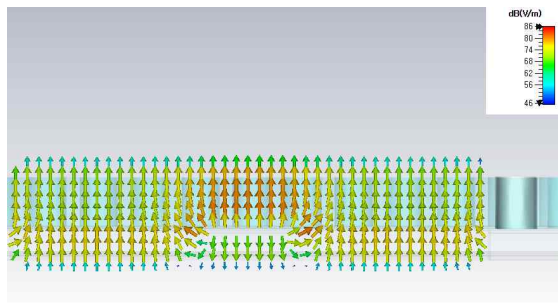

Fig. 7. Electric field on a cross section of the feed line

Fig. 7 shows the electric field distribution on the CPW feed line. The characteristic impedance of the line is 50Ω . Fig. 8 shows the electric field distribution around the patch when one of the feed line is excited while the other is terminated with a matched load. One can observe a good polarization uniformity. Fig. 9 shows the corresponding electric field distribution at a cross section of the square waveguide. Again the polarization purity is high containing only the TE_{10} mode field.

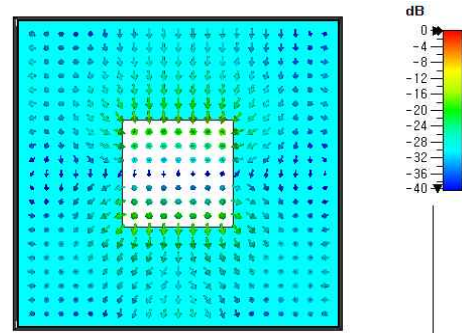

Fig. 8. Electric field around the microstrip patch

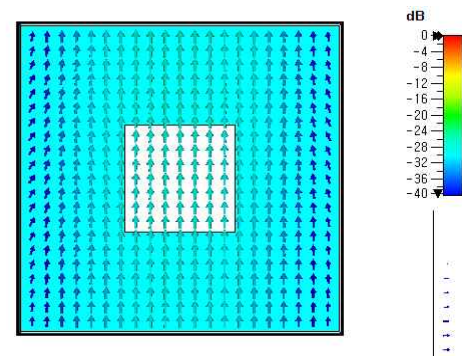

Fig. 9. Electric field on the square waveguide cross section

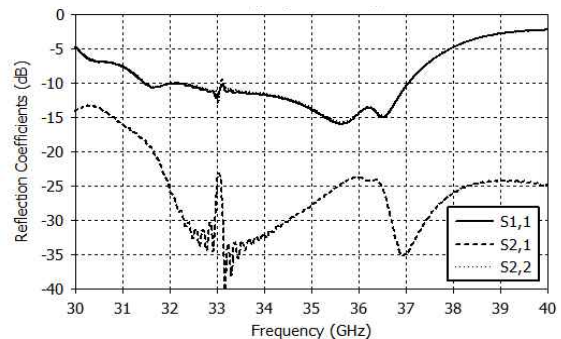

Fig. 10. Reflection and coupling coefficients of the designed antenna

Fig. 10 shows the port reflection coefficient and the port-to-port coupling coefficient (or the negative of the port isolation). At 35-37 GHz, the reflection and port-to-port coupling are less than -10 dB and -24 dB respectively. Fig. 11 shows the three-dimensional gain patterns of the designed antenna at 35 GHz. One can observe a reasonably good angular symmetry in the gain pattern. Figs. 12-13 show the co-polarization gain in the E - and H -planes and the cross-polarization gain

in the diagonal planes at 35 and 37 GHz. For the co-polarized radiation, the gain ranges from 9.5 to 9.9 dBi while the cross polarization at boresight ranges from -25 to -18 dBi resulting in cross polarization discrimination greater than 20 dB. The front-to-back ratio is 28 dB at 35 GHz and 35 dB at 37 GHz. The final design of the proposed antenna meets all the design requirements in Table 1.

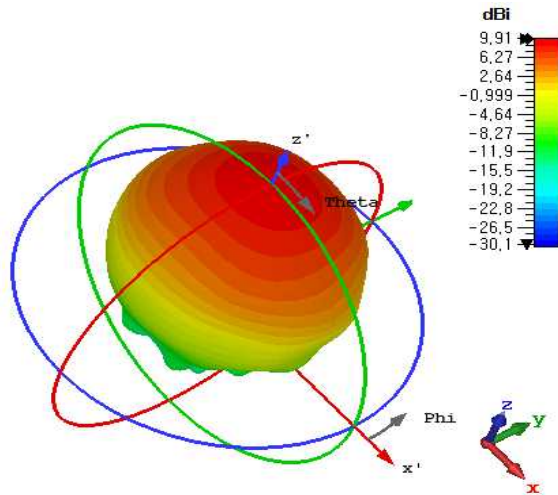
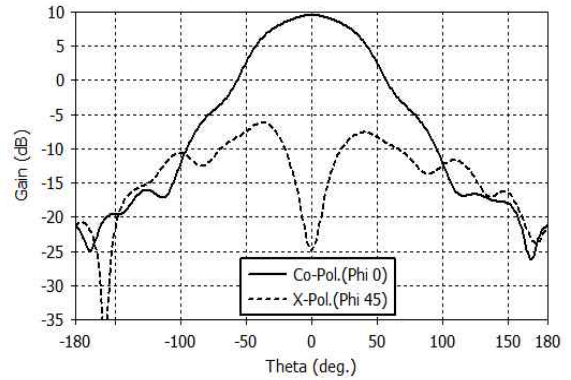
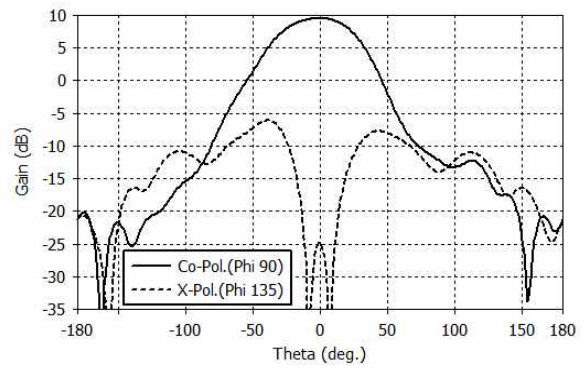

Fig. 11. 3D gain pattern of the designed antenna



(a) *E*-plane co-pol & 45°-plane x-pol



(b) *H*-plane co-pol & 135°-plane x-pol

Fig. 13. Gain patterns of the designed antenna at 35 GHz

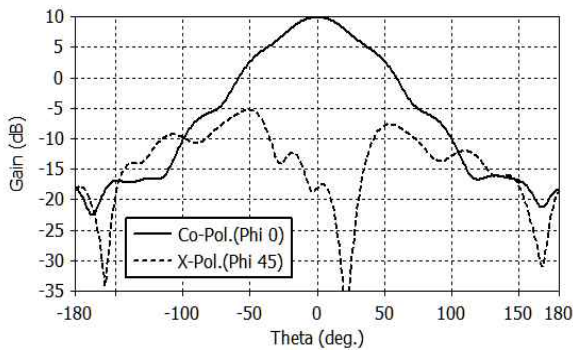

(a) *E*-plane co-pol & 45°-plane x-pol

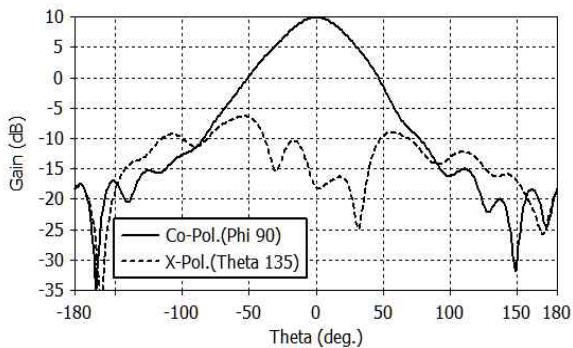

(b) *H*-plane co-pol & 135°-plane x-pol

Fig. 12 Gain patterns of the designed antenna at 35 GHz

III. Conclusion

A dual-polarized square waveguide antenna has been designed that has good characteristics at 35-37 GHz. A proximity-coupled dual-CPW fed square patch has been designed to excite the orthogonal TE_{10} and TE_{01} modes in the square waveguide. The bandwidth limitation of the patch antenna has been solved by feeding the patch with proximity coupling from the back side and by backing the patch with an air-filled cavity. At desired 35-37 GHz frequency range, the designed antenna has reflection coefficient of less than -10 dB, port-to-port isolation of greater than 24 dB, and boresight cross-polarization discrimination of greater than 28 dB. The antenna design presented in this paper may be employed as a dual-polarized reflector antenna feed and a radiating element in a dual-polarized waveguide array antenna.

References

- [1] R. M. Yang, K. Atanassov, V. Stoiljkovic, and G. R. Kadambi, "Polarization diversity measurements and analysis for antenna configurations at 1800 MHz", *IEEE Trans. Antennas Propagat.*, Vol. 52, No. 7, pp. 1795-1810, Jul. 2004.
- [2] A. Shen, B. C. Ahn, S. J. Shin, Y. H. Cho, and K. H. Oh, "Design of a W-band seeker antenna employing a dielectric-rod feed", *Journal of KIIT*, Vol. 16, No. 2, pp. 83-91, Feb. 2018.
- [3] Q. Zhang and W. Pan, "Adaptive countering technique for angle deception based on dual polarization radar seeker", *International Journal of Antennas and Propagation*, Vol. 2017, Article ID 2345491, 8pages, 2017. <https://doi.org/10.1155/2017/2345491>.
- [4] G. N. Tsandoulas and G. H. Knittel, "The analysis and design of dual-polarization square-waveguide phased arrays", *IEEE Transactions on Antennas and Propagation*, Vol. 21, No. 6, pp. 796-808, Nov. 1973.
- [5] R. W. Jackson, "A planar orthomode transducer", *IEEE Microwave and Wireless Components Letters*, Vol. 11, No. 12, pp. 483-485, Dec. 2001.
- [6] S. Ononchimeg, G. Otgonbaatar, J. H. Bang, and B. C. Ahn, "A new dual-polarized horn antenna excited by a gap-fed square patch", *Progress In Electromagnetics Research Letters*, Vol. 21, pp. 128-137, Jan. 2011.
- [7] G. M. Coutts, "Octave bandwidth orthomode transducers for the expanded very large array", *IEEE Transactions on Antennas and Propagation*, Vol. 59, No. 6, pp. 1910-1917, Jun. 2011.
- [8] A. Navarrini, C. Gropper, and G. Chattopadhyay, "A waveguide orthomode transducer for 385-500 GHz", *21st International Symposium on Space Terahertz Technology 2010*, Oxford, United Kingdom, pp. 328-337, Mar. 2010.

Authors

Songyuan Xu



2017. 8 : B.S. Communications Engineering, Chungbuk National University
 2018 ~ present : M.S. Student, Radio and Communications Eng., Chungbuk National University

Research interests : Antennas, applied EM

Ariunbold Galsan Yondon



2011 ~ 2015 : B.S. Power Engineering School, Mongolian University of Science and Technology
 2017 : M.S. Power Engineering School, Mongolian University of Science and Technology

2018 ~ present : Ph.D Student, Radio and Communications Eng., Chungbuk National University
 Research interests : Antennas, microwave engineering.

Shu Li



2014. 8 : B.S. Communications Engineering, Chungbuk National University
 2016. 8 : M.S. Student, Radio and Communications Eng., Chungbuk National University
 2019. 8 : Ph.D Student, Radio and Communications Eng., Chungbuk National University

Research interests : Antennas, applied EM

Bierng-Chearl Ahn



1992. 12 : Ph. D., Electrical Eng., University of Mississippi.
 1992 ~ 1994 : Researcher, Agency for Defense Development
 1995 ~ Present : Professor, Radio and Communications Eng., Chungbuk National University

Research interests : Antennas, applied EM